

# OWNER'S GUIDE &

# INSTALLATION INSTRUCTIONS

## Transom-Mount *with* Integral Release Bracket Transducer *or* TRIDUCER® Multisensor

Models: P23, P32

Record the information found on the cable tag for future reference.

Part No. \_\_\_\_\_ Date \_\_\_\_\_ Frequency \_\_\_\_\_ kHz

04/07/11

17-122 rev. 07

**WARNING:** Always wear safety goggles and a dust mask when installing to prevent personal injury.

**WARNING:** When the boat is placed in the water, immediately check for leaks around the screws and any other holes drilled in the hull.

**CAUTION:** Never pull, carry, or hold the transducer by the cable as this may sever internal connections.

**CAUTION:** Never strike the sensor with anything except the palm of the hand. Never strike the paddlewheel.

**CAUTION:** Never use solvents. Cleaners, fuel, paint, sealants, and other products may contain strong solvents, such as acetone, which attack many plastics greatly reducing their strength.

**IMPORTANT:** Please read the instructions completely before proceeding with the installation. These instructions supersede any other instructions in your instrument manual if they differ.

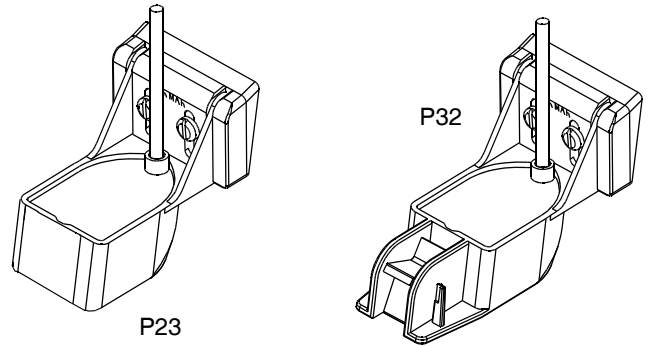

### Pretest Temperature & Speed Functions

Connect the sensor to the instrument and spin the paddlewheel. Check for the approximate air temperature and a speed reading. If there is no reading(s) or it is inaccurate, check the connections and test again. If there is still a problem, return the product to your place of purchase.

### Mounting Location

**CAUTION:** Do not mount in an area of turbulence or bubbles: near water intake or discharge openings; behind strakes, struts, fittings, or hull irregularities

**CAUTION:** Avoid mounting the sensor where the boat may be supported during trailering, launching, hauling, or storage.

- For the best performance, the sensor must be in contact with smooth water. To identify an area of clean water, observe the water flow off the transom while the boat is underway.
- Allow headroom space above the bracket for it to release and rotate the sensor upward.
- Mount the sensor as close to the centerline (keel) of the boat as possible to ensure the sensor remains in the water when the boat is turning.
  - **Single drive boat**—Mount at least 75 mm (3") beyond the swing radius of the propeller (see Figure 2). The starboard side where the propeller blades are moving downward is preferred.
  - **Twin drive boat**—Mount the sensor between the drives.

### Applications

- Not recommended for boats with large inboard engine(s)
- Not recommended for stepped hull
- Good operation up to 55kn (63MPH)
- Vertically orients sound beam on hull with deadrise angle up to 30°
- Adjusts to transom angles from 3° – 20°
- Bracket protects sensor from frontal impact only

### Tools & Materials

Safety goggles

Dust mask

Scissors

Masking tape

Electric drill

Drill bits:

Bracket holes 4mm, #23, or 9/64"

Transom hole (optional) 18mm, 11/16", or 3/4"

Cable clamp holes 3mm or 1/8"

Straight edge

Wire cutters (some installations)

Marine sealant (suitable for below waterline)

Screwdrivers

Pencil

Zip-ties

Water-based antifouling paint (**mandatory in salt water**)

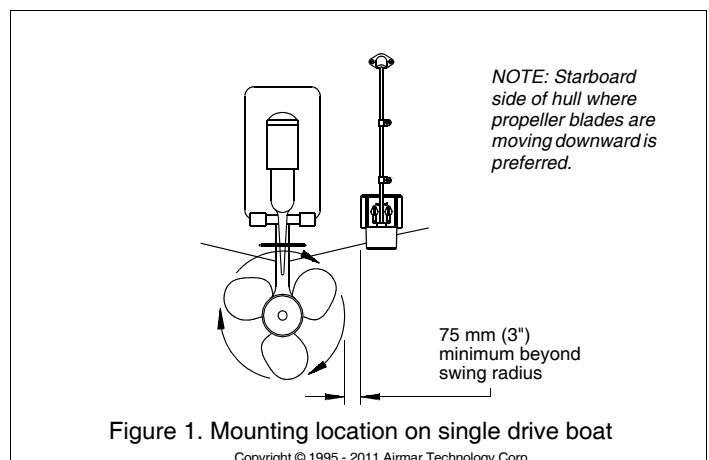

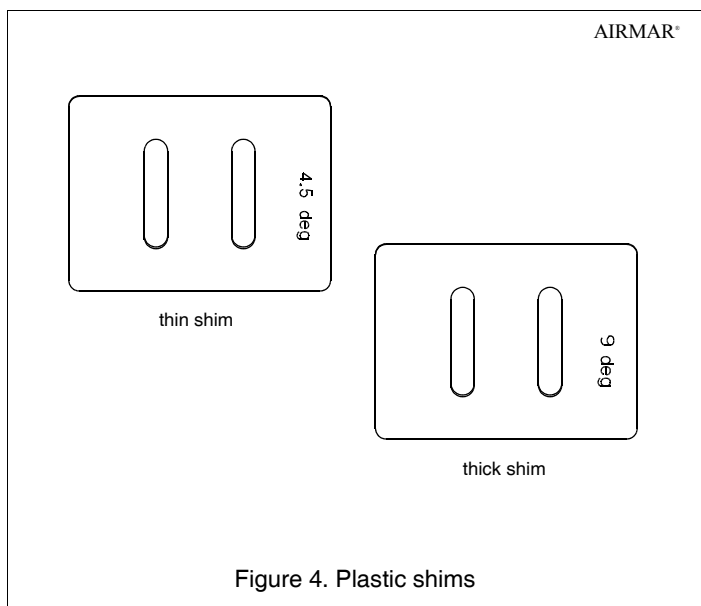
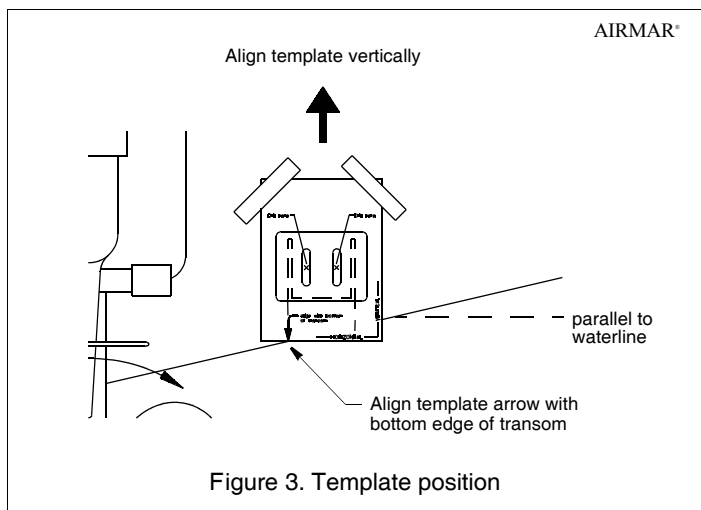
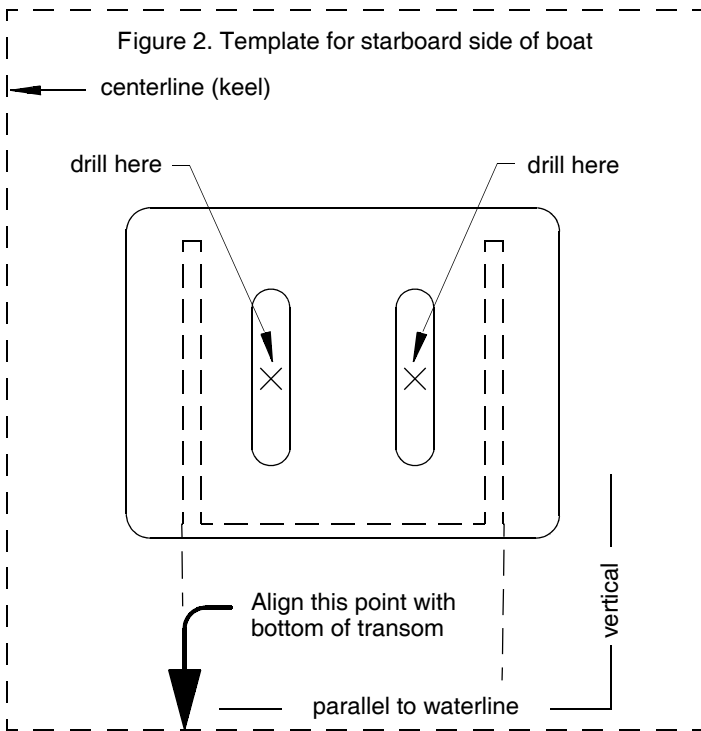

## Installation

### Assembling & Positioning

1. Insert the top of the sensor's pivot posts into the slots on the top back of the bracket. Rotate the bracket down until the bottom snaps onto the sensor.
2. Cut out the template (see Figure 2).
3. At the selected location on the starboard side of the hull, position the template so the arrow at the bottom is aligned with the bottom edge of the transom (see Figure 3). *Being sure* the template is parallel to the waterline, tape it in place.

### Hole Drilling

Using a 4mm, #23, or 9/64" bit, drill two holes 22mm (7/8") deep at the locations indicated. To prevent drilling too deeply, wrap masking tape around the bit 22mm (7/8") from the point.

**Fiberglass hull**—Minimize surface cracking by running the drill in reverse until the gelcoat is penetrated.

### Plastic Shims

- **Standard transom** (13° transom angle)—The bracket is designed for a standard 13° transom angle. The *9 degree* shim is *not* needed for this installation. If your boat is capable of speeds above 35kn (40MPH), install the bracket with the *4.5 degree* shim, taper *down* (see Figures 4 and 5). This ensures that the paddlewheel will be in contact with the water at high speeds.
- **Stepped transom and jet boats** (3° transom angle) —Use the *9 degree* shim with the taper *down* (see Figures 4 and 5).
- **Small aluminum and fiberglass boats** (20° transom angle)—Use the *9 degree* shim with the taper *up* (see Figures 4 and 5).
- **If you are unsure about using the shims**—To determine if the *9 degree* shim is needed, position the sensor at the selected location. Using a straight edge, sight the underside of the sensor relative to the underside of the hull (see Figures 4 and 5). The trailing edge of the sensor should be 1–3mm (1/16–1/8") below the leading edge of the sensor or parallel to the bottom of the hull.

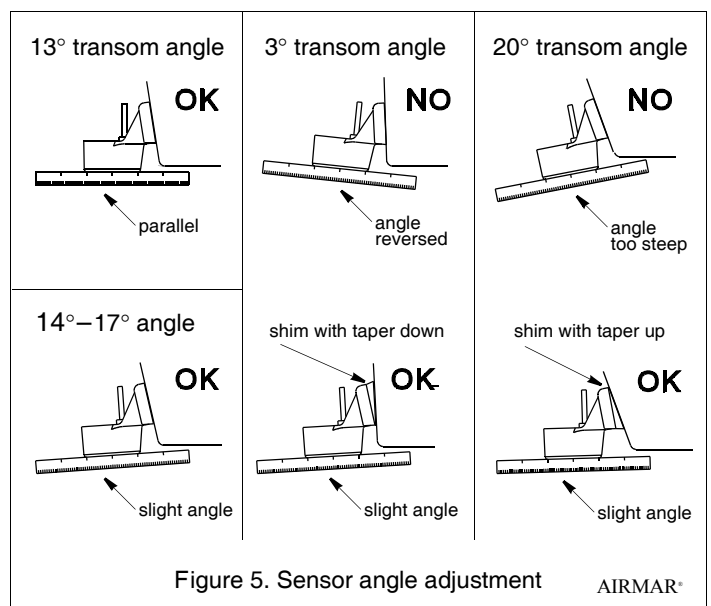

## Mounting & Adjusting

**CAUTION:** Do not position the leading edge of the sensor lower than the trailing edge because aeration will occur.

**CAUTION:** Do not position the sensor farther into the water than necessary to avoid increasing drag, spray, and water noise and reducing boat speed.

1. Align the posts on the shim with the two holes in the bracket. Snap the shim into place.

**High-speed operation** [above 35kn (40MPH)]—It may be necessary to install the bracket with both shims to ensure that the paddlewheel will be in contact with the water at high speeds. Remove the posts from the 4.5 degree shim with wire cutters. Place the 4.5 degree shim, taper *down*, behind the 9 degree shim.

2. Apply a marine sealant to the threads of the two #10 x 1-1/4" self-tapping bracket screws to prevent water seepage into the transom. With the shim(s) in place, screw the bracket to the hull. *Do not tighten the screws completely at this time.*
3. Using a straight edge, sight the underside of the sensor relative to the underside of the hull (see Figure 5). The trailing edge of the sensor should be 1–3mm (1/16–1/8") below the leading edge of the sensor or parallel to the bottom of the hull.
4. Using the vertical adjustment space in the bracket slots, slide the sensor up or down until the bottom left corner of the sensor projects 3mm (1/8") below the bottom of the hull (see Figure 6). When you are satisfied with the position of the sensor, tighten the screws.

## Testing on the Water

1. Become familiar with your echosounder's performance at a speed of 4kn (5MPH).
2. Gradually increase the boat speed and observe the gradual decline in performance due to turbulent water flowing over the transducer's active surface.
3. If the decline in performance is sudden (not gradual), identify the boat speed at which the onset occurred. Return the boat to this speed, then gradually increase speed while making moderate turns in both directions.
4. If the performance improves while turning to the side on which the sensor is installed, its position probably needs adjustment. It is probably in aerated water.

**To improve performance**, try the following *one at a time* in the order given.

- A. Move the multisensor farther into the water in increments of 3mm (1/8") (see Figure 4).
- B. High-speed operation above 35kn (40MPH) may be improved by less projection in the water. Move the sensor upward on the transom.
- C. Increase the multisensor's angle in the water. Install the 4.5° shim with the taper *down* (see Figure 5).
- D. Move the multisensor closer to the centerline of the boat. Fill unused screw holes with marine sealant.

## Cable Routing

**CAUTION:** Do not remove the connector to ease cable routing. If the cable must be cut and spliced, use Airmar's splash-proof Junction Box No. 33-035 and follow the instructions provided. Removing the waterproof connector or cutting the cable, except when using a water-tight junction box, will void the sensor warranty.

Route the sensor cable over the transom, through a drain hole or through a new hole drilled in the transom **above the waterline**.

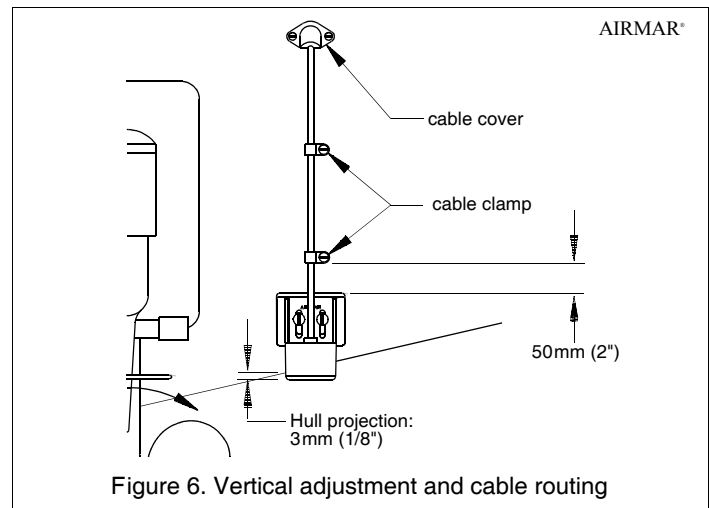

1. If a hole must be drilled through the transom, choose a location **well above the waterline** (see Figure 6). Check for obstructions such as trim tabs, pumps or wiring inside the hull. Mark the location with a pencil. Drill a hole using the appropriate size bit to accommodate the connector.
2. Route the cable over or through the transom.
3. On the outside of the hull secure the cable against the transom using the cable clamps. Position one cable clamp 50mm (2") above the bracket and mark the mounting hole with a pencil.
4. Position the second cable clamp halfway between the first clamp and the cable hole. Mark this mounting hole.
5. If a hole has been drilled in the transom, open the appropriate slot in the cable cover. Position the cover over the cable where it enters the hull. Mark the two screw holes.
6. At each of the marked locations, use a 3mm or 1/8" bit to drill a hole 10mm (3/8") deep. To prevent drilling too deeply, wrap masking tape around the bit 10mm (3/8") from the point.
7. Apply marine sealant to the threads of the #6 x 1/2" self-tapping screws to prevent water from seeping into the transom. If you have drilled a hole through the transom, apply marine sealant to the space around the cable where it passes through the transom.
8. Position the two cable clamps and fasten them in place. If used, push the cable cover over the cable and screw it in place.
9. Route the cable to the instrument *being careful* not to tear the cable jacket when passing it through the bulkhead(s) and other parts of the boat. To reduce electrical interference, separate the sensor cable from other electrical wiring and the engine(s). Coil any excess cable and secure it in place with zip-ties to prevent damage.
10. Refer to your echosounder owner's manual to connect the sensor to the instrument.

## Checking for Leaks

When the boat is placed in the water, **immediately** check for leaks around the screws and any holes drilled in the hull. Note that very small leaks may not be readily observed. Do not leave the boat in the water unchecked for more than three hours.

## Maintenance

### Antifouling Paint

Aquatic growth can accumulate rapidly on the sensor's surface reducing performance within weeks. Surfaces exposed to salt water that do not interlock, must be coated with antifouling paint. Use **water-based** antifouling paint only. Never use ketone-based paint, since ketones can attack many types of plastic possibly causing damage to the transducer. Apply paint every 6 months or at the beginning of each boating season.

### Cleaning

Clean the assembly with a soft cloth and mild household detergent. If fouling occurs, use a stiff brush or putty knife to remove the growth being careful to avoid making scratches on the transducer face. In severe cases, wet sand the surface with fine grade wet/dry paper.

### Servicing the Paddlewheel

**CAUTION:** The paddlewheel must be oriented correctly to measure boat speed.

If the P32 paddlewheel becomes fouled or inoperable, it can be removed for cleaning. Gently push back one retaining arm and slide the shaft out.

Orient the short side of the paddlewheel blades as shown in Figure 7. Reinsert the shaft in the lower set of holes by pushing back on the retaining arms. *Be sure the shaft ends are secure in the retaining arm notches.*

### Sensor Replacement, Parts & Accessories

The information needed to order a replacement Airmar sensor is printed on the cable tag. Do not remove this tag. When ordering, specify the part number, date, and frequency. For convenient reference, record this information on the top of page one.

Lost, broken, or worn parts should be replaced immediately. The water-lubricated paddlewheel bearings have a life of up to 5 years on low-speed boats [less than 10kn (11MPH)] and 2 years on high-speed vessels. Purchase parts from your marine dealer or instrument manufacturer.

Paddlewheel Kit	33-007
Bracket & Wedge Kit	20-154-04
Portable Bracket Kit (see Figure 8)	33-173

Obtain parts from your instrument manufacturer or marine dealer.

Gemeco (USA)	Tel: 803.693.0777 Fax: 803.693.0477 email: sales@gemeco.com
Airmar EMEA (Europe, Middle East, Africa)	Tel: +33.(0)2.23.52.06.48 Fax: +33.(0)2.23.52.06.49 email: sales@airmar-emea.com

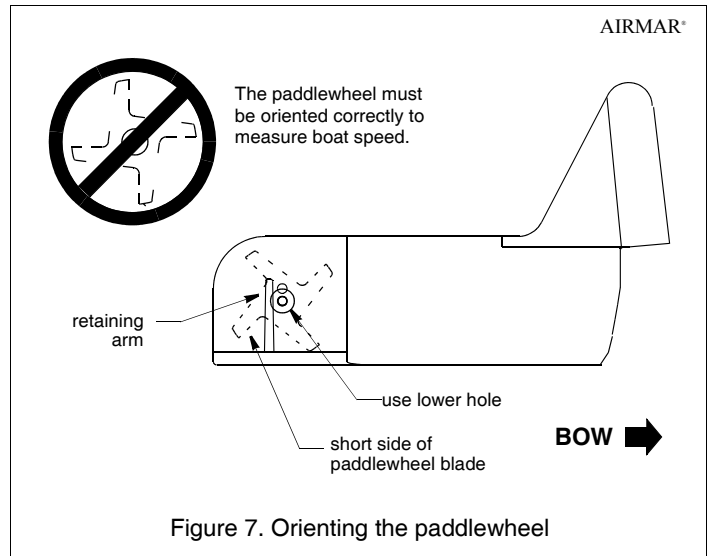

Figure 7. Orienting the paddlewheel



Figure 8. Portable Bracket Kit 33-173